

NEW: Tool holder with level of the GSR think tank

Dear customer,

In newsletter no. 9 GSR presents our newest innovation: tool holder with level. Yes, tool holder with ratchet is not an innovation! What is the difference to the GSR-standard tool holder? The answer: Precision is in the detail even though by the new tool holder.

The "clou": an integrated spirit level, it helps to adjust the vertical position of the tap to achieve a better cutting result.

The tool holder with level is also available in the extra long versions. Please check the following description for the tool holder with ratchet. Enjoy reading our latest information from the GSR think tank.

For wishes or suggestions we shall be pleased to receive your opinion.

Your GSR-Team



▶ TOOL HOLDER WITH RATCHET

General information about the toolholder with ratchet

As well as the standard tool holder, the new ratchet, is also equipped with a shift to reverse the working direction. The handle has three setting positions, also usable to work in difficult positions. The clamping chuck as well as the head of the tool holder has a knurled surface to get more grip. The true innovation is hidden in the head of the tool holder.

The recessed spirit level is the guide for vertically correct adjustment of the hand tap. The cutting result is more precise. This new tool holder is not only usable for hand taps. You can span all tools with square shank.

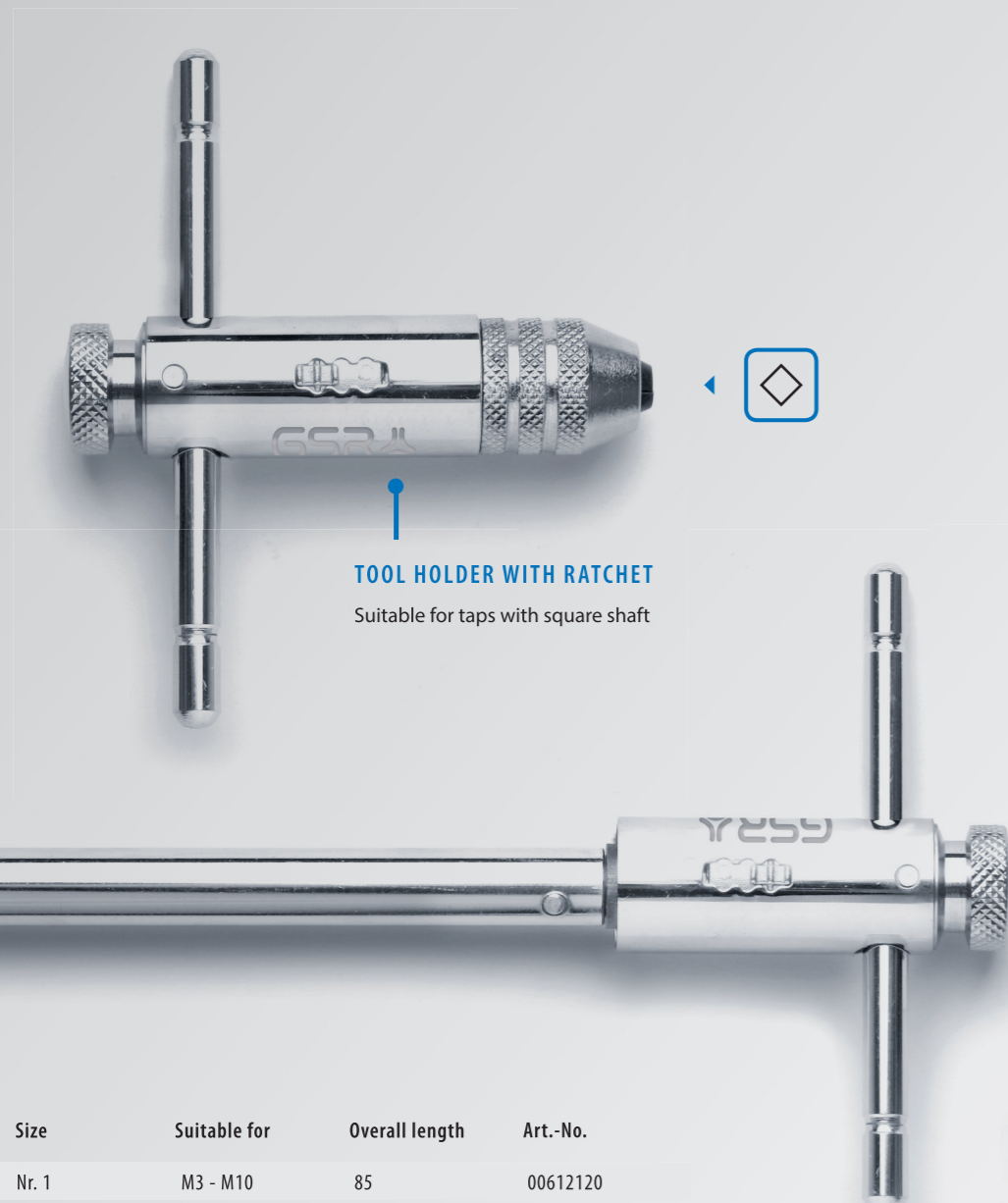

TOOL HOLDER WITH RATCHET

Suitable for taps with square shaft

Size	Suitable for	Overall length	Art.-No.
Nr. 1	M3 - M10	85	00612120
Nr. 2	M5 - M12	100	00612130
Long version			
Nr. 10	M3 - M10	250	00614120
Nr. 20	M5 - M12	300	00614130

▶ EXPLODED VIEW

Tool holder with ratchet and centering lug

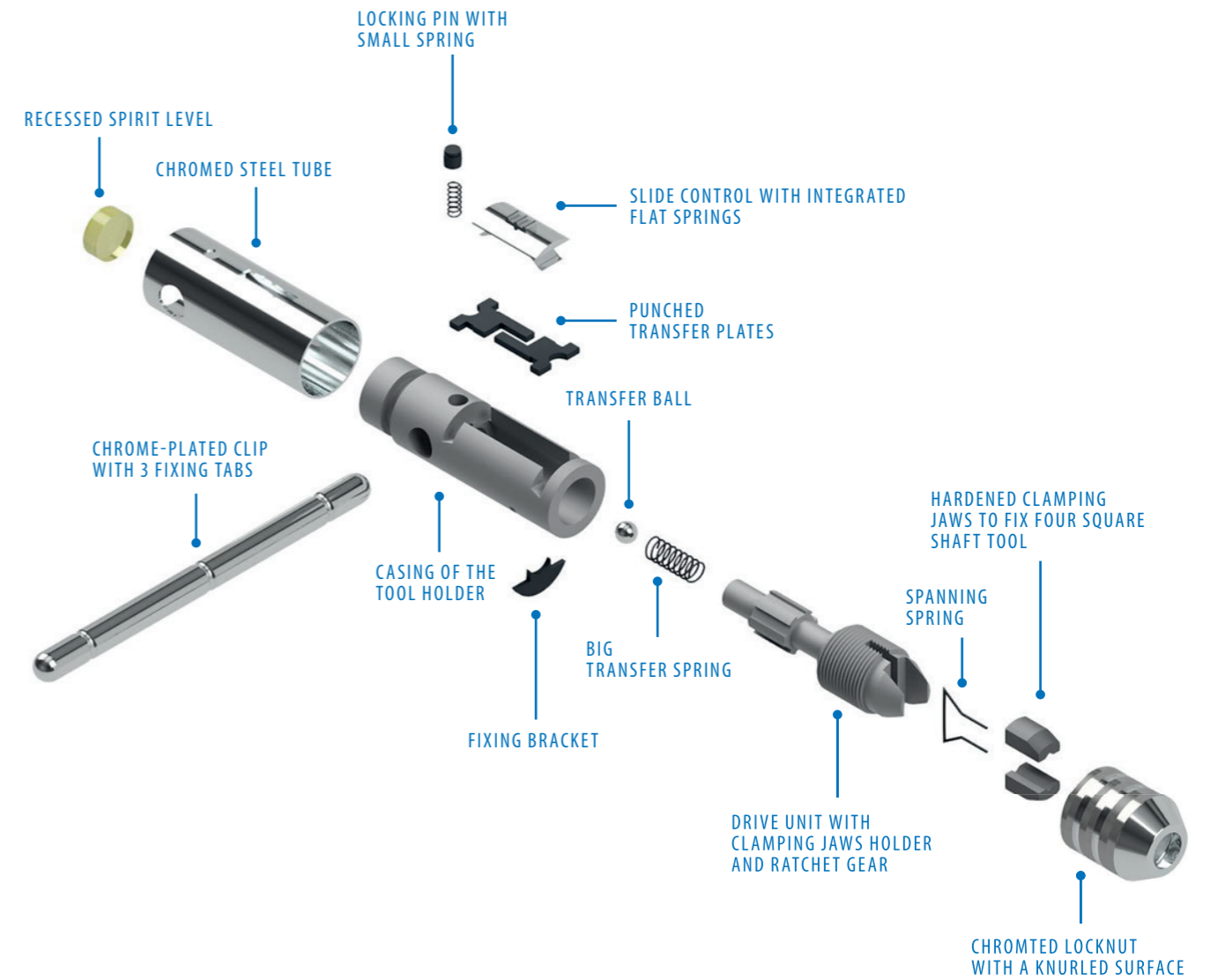

new application with the tool holder

Following we show the correct adjustment
with the spirit level.

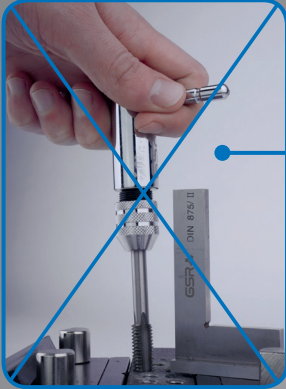

Do you have also
problems with the
vertical correct
adjustment?

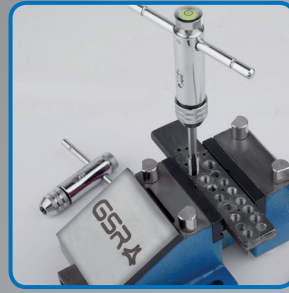

1. start smoothly to
fix the tap into the
tapping sized hole

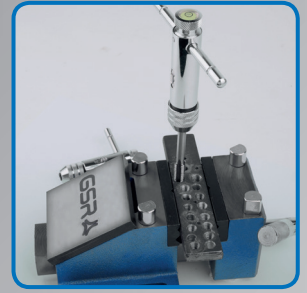

2. carefully turning and
adjust the holder

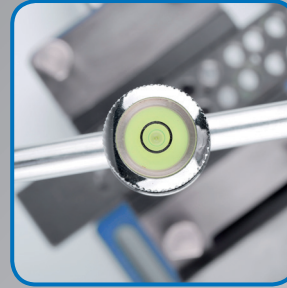

3. center the level
bubble to the
middle of the circle

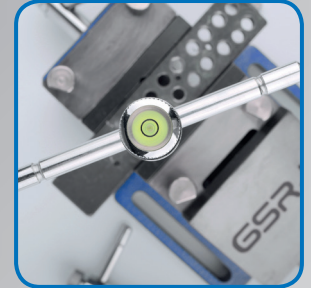

4. start tapping

securing future by apprenticeship

Even business trainees are regularly trained
in using our tools.

They secure the development and consist the
future of our customer and our company, too.



WWW.GSR-GERMANY.DE

GSR 

Industriegebiet Blaffertsberg Schmiedestraße 4 42899 Remscheid Fon 02191 / 5833 Fax 02191 / 52769 Mail info@gsr-germany.de

Precision is in the Detail. Since 1889.

THREADING TOOLS
Gustav Stursberg